

## INTRODUCTION

Western manifold systems are cleaned, tested and prepared for the indicated gas service and are built in accordance with the Compressed Gas Association guidelines. The manifold is specifically designed to regulate and monitor vaporized gas from cryogenic liquid cylinders. When the gas from the cryogenic cylinders is depleted the manifold will automatically permit the gas to flow from the reserve high pressure cylinders. This ensures an uninterrupted supply of gas to the application. The manifold consists of a high pressure header and regulator (MS style), an adjustable cryogenic line regulator, 72" cryogenic flexible pigtails with check valves, rigid wall mounted headers, a port for an optional pressure switch and complete mounting hardware.

## CAUTION

### Failure to follow the following instructions can result in personal injury or property damage:

- Never permit oil, grease, or other combustible materials to come in contact with cylinders, manifold, and connections. Oil and grease may react and ignite when in contact with some gases — particularly oxygen and nitrous oxide.
- Cylinder, header, and master valves should always be opened very s-l-o-w-l-y. Heat of recompression may ignite combustible materials.
- Pigtails should never be kinked, twisted, or bent into a radius smaller than 3 inches. Mistreatment may cause the pigtail to burst.
- Do not apply heat. Some materials may react and ignite while in contact with some gases — particularly oxygen and nitrous oxide.
- Cylinders should always be secured with racks, chains, or straps. Unrestrained cylinders may fall over and damage or break off the cylinder valve which may propel the cylinder from its current position with great force.
- Oxygen manifolds and cylinders should be grounded. Static discharges and lightning may ignite materials in an oxygen atmosphere, creating an explosive force.
- Welding should not be performed near nitrous oxide piping. Excessive heat may cause the gas to dissociate, creating an explosive force.
- Carefully read and follow installation and operating instructions! Manifolds are designed for gas withdrawal from cryogenic liquids. Contact with a cryogenic gas or liquid with skin or eyes may cause a freezing injury.

## WARRANTY

All Western manifolds are warranted against defects in materials and workmanship for the period of one year from date of purchase. See back cover for details of limited warranty.

## TABLE OF CONTENTS

GENERAL INSTRUCTIONS .....	3
MANIFOLD ASSEMBLY .....	4
MANIFOLD INSTALLATION.....	4
PLUMBING .....	5
INSTALLATION OF OPTIONAL EQUIPMENT .....	6
PRESSURE SWITCH INSTALLATION .....	6
INSTALLING PIGTAILS AND ATTACHING CYLINDERS .....	6
REMOTE ALARM HOOKUP .....	7
START UP AND CHECKING PROCEDURES.....	8
MANIFOLD OPERATION .....	9
CYLINDER REPLACEMENT & HANDLING .....	10
GENERAL MAINTENANCE .....	11
TROUBLE-SHOOTING .....	12
MANIFOLD MAINTENANCE & REPAIR PARTS .....	13
REPLACEMENT PIGTAILS .....	13
REGULATORS AND REGULATOR REPAIR KITS.....	13
VALVES AND VALVE REPAIR KITS .....	13
WARRANTY .....	14

**GENERAL INSTRUCTION**

Manifolds should be installed in accordance with guidelines stated by the National Fire Protection Association, the Compressed Gas Association, OSHA, Canadian Standards Association, and all applicable local codes. The carbon dioxide and nitrous oxide manifolds should not be placed in a location where the temperature will exceed 120°F (49°C) or fall below 20°F (-7°C). The manifolds for all other gases should not be placed in a location where the temperature will exceed 120°F (49°C) or fall below 0°F (-18°C). A manifold placed in an open location should be protected against adverse weather conditions including direct rain, snow, and heavy moisture. During winter, protect the manifold from ice and snow. In summer, shade the manifold and cylinders from continuous exposure to direct rays of the sun.

Leave all protective covers in place until their removal is required for installation. This precaution will keep moisture and debris from the piping interior, avoiding operational problems.

**CAUTION:**

- Remove all protective caps prior to assembly. The protective cap may ignite due to heat of recompression in oxygen systems.

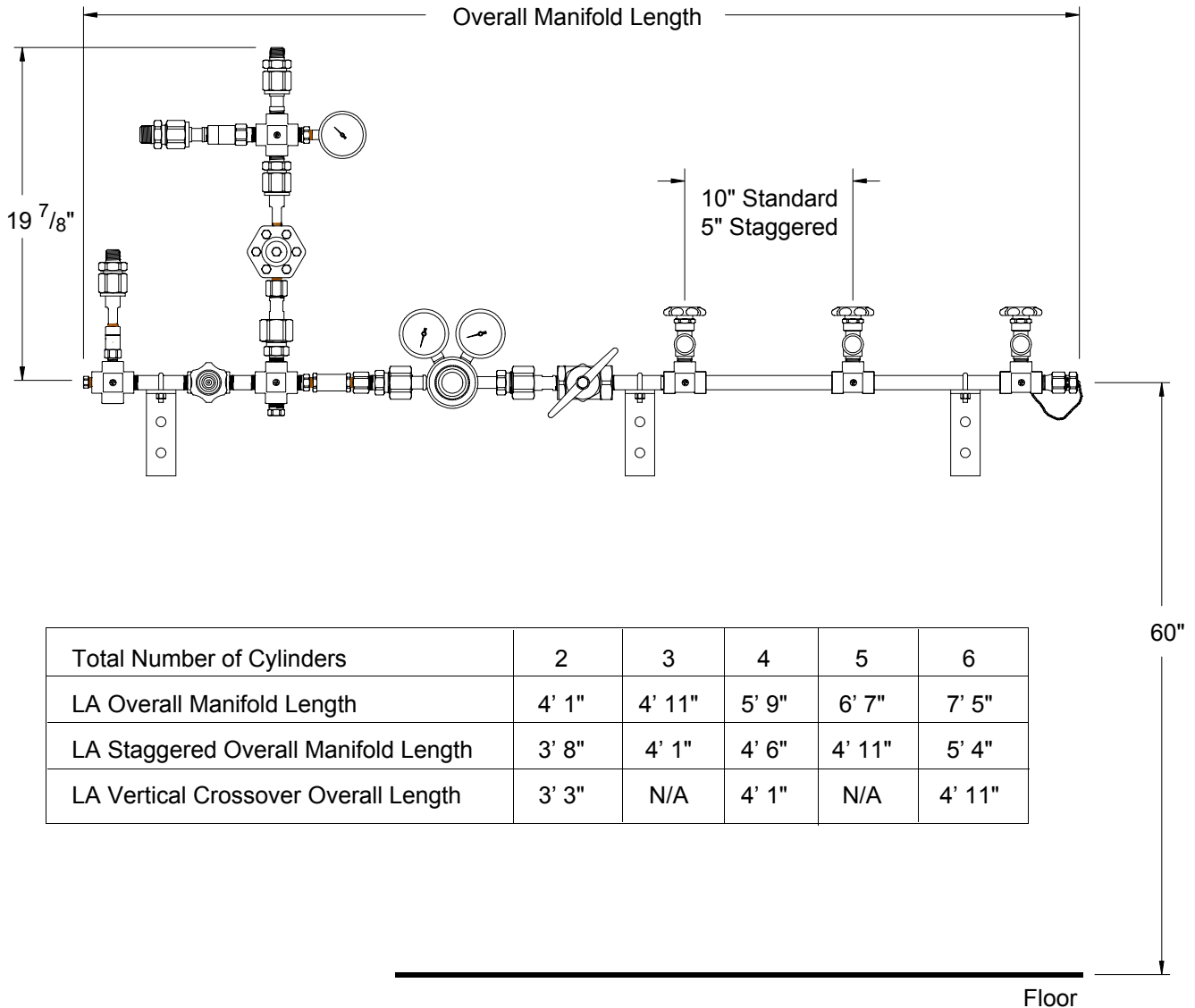

FIGURE 1

## MANIFOLD ASSEMBLY

1. Assemble the header assembly to the regulator inlet oriented as shown in Figure 2.

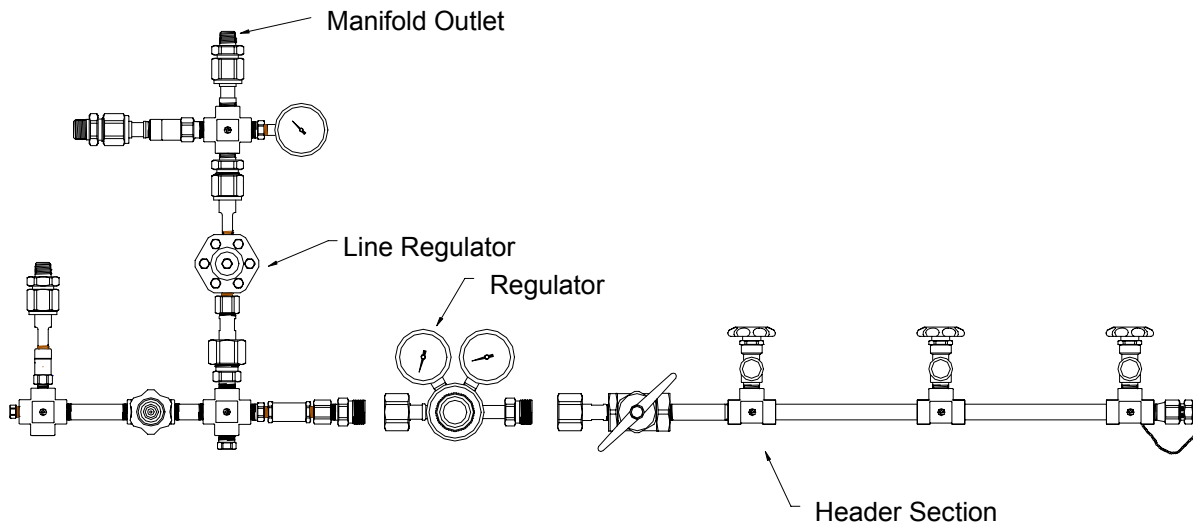

FIGURE 2

## MANIFOLD INSTALLATION

1. Determine and mark the vertical center line for installation of the manifold (Figure 2). This centerline will indicate where the vertical portion of the manifold will be located.

2. Measure from the floor to a point 60" in height\* on vertical line. Using a level, mark a horizontal line at this point extending approximately 55" to the right 10" to the left of center.

(\*Suggested manifold height. Wall mounting heights may vary from one installation to another depending on available space, cylinder height, etc.)

3. Mark another vertical line 7" to the left of the center line.
4. Mark a vertical line 22" to the right of the center line.

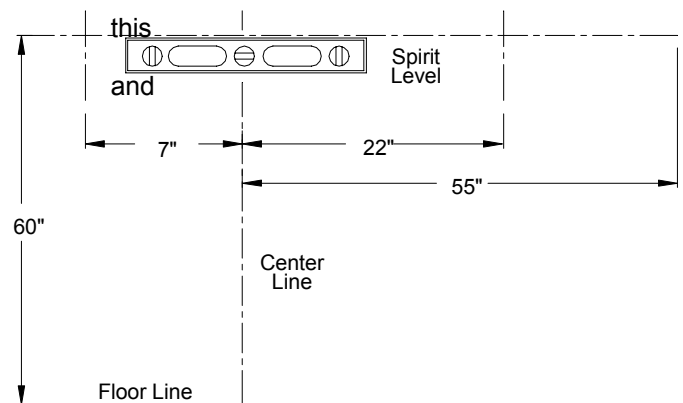

5. Remove the U-bolt assemblies from the mounting brackets. Position the first bracket so that the top of the bracket is aligned with the horizontal line and centered on the right vertical line.

6. Mark the mounting holes and install fasteners suitable for the type of wall construction. (Figure 4)

7. Measure the header and mark a distance that would place the bracket near the end of the high pressure reserve manifold header.

8. Mark the mounting holes and install fasteners suitable for the type of wall construction. (Figure 4)

9. Mount the high pressure reserve manifold by placing the header on bracket. Fit the U-bolt over the header pipe and tighten the mounting nuts. (Figure 5)

10. Using a level, mark the placement of any additional mounting while keeping the header on a horizontal plane. (Figure 5)

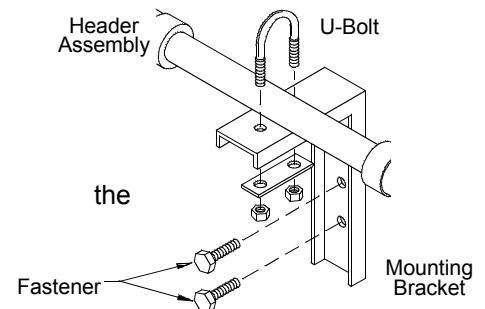

FIGURE 4

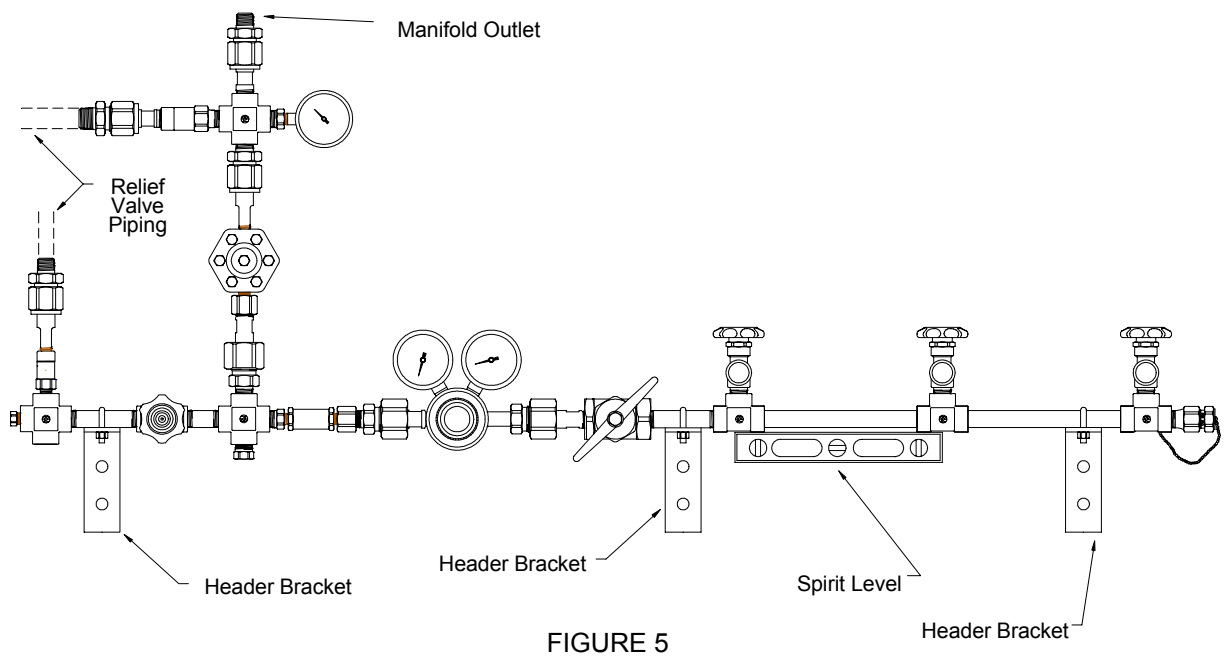

FIGURE 5

11. Remove the U-bolt assemblies from the header mounting brackets. Position the brackets so that the top of the bracket is aligned with the bottom of the headers and is centered between the header inlets. Brackets should be equally spaced to provide the most support and stability.
12. Mark the mounting hole and install fasteners suitable for the type of wall construction. (Figure 4)
13. Fit the U-bolt over the header piping and tighten the two mounting nuts.

**PLUMBING**

1. A 1/2" NPT male union is supplied with the control and is located at the outlet of the manifold. Connect this union to the pipeline system. The union provided permits removal of the manifold for service. (Figure 5)
2. If the manifold is installed in an enclosed area, vent piping should be attached to the manifold relief valves. The vent connections are 1/2" NPT male and 3/4" NPT male.

## INSTALLATION OF OPTIONAL EQUIPMENT

### PRESSURE SWITCH

1. Install an orifice bushing into the 1/2 NPT cross (Figure 6).
2. Install the pressure switch onto the orifice bushing (Figure 6).

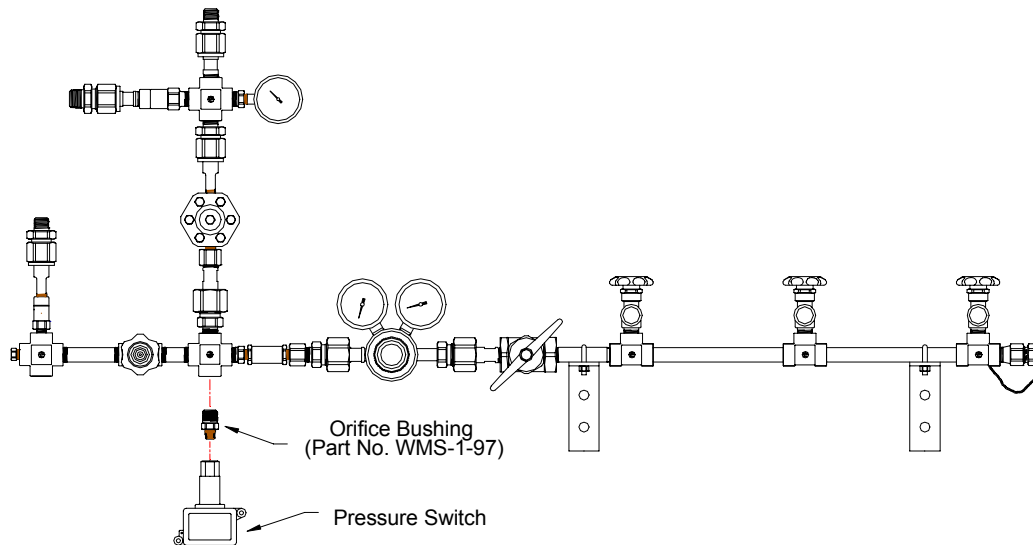

FIGURE 6

### INSTALLING PIGTAILS AND ATTACHING CYLINDERS

1. Establish the high pressure and cryogenic pigtails. The cryogenic pigtails are 72" long and have a 1/4 NPT outlet fitting. The high pressure pigtails are 24" and 36" long and have gas specific CGA connections at each end.
2. Establish the flow direction of the check valve in the pigtails.
3. Connect the manifold end (outlet end) of the pigtails to the manifold header, then connect the inlet end to the cylinder.
4. Check the master valve to be certain it is open.
5. Back out both the line regulator and the high pressure regulator adjusting screws. This will protect the system from being over pressurized when opening cylinders.
6. Open header valves (turn counter-clockwise to open). Note; Oxygen manifolds have check valves instead of header valves.
7. Attach full cylinders to the pigtail connections as explained in "Cylinder Replacement & Handling" on page 10.
8. S-L-O-W-L-Y turn all cylinders on fully (turn counter-clockwise to open). Check all cylinder and pigtail connections for leaks using Western leak detector LT-100 or an oxygen safe solution. (Any bubbles around connections indicate leakage.)

**REMOTE ALARM HOOKUP**

Western LA manifolds may be connected to an alarm system provided a pressure switch is installed into the manifold. The pressure switch provides isolated (dry) remote alarm contacts. Wiring diagrams for remote audio/visual alarms are included with the alarms. Listed below are three different remote alarm configurations.

**WESTERN'S ALARM**

1. Western's alarms (BIA-1, BIA-2, and BIA-3) require a 24 VAC power supply (P/N WMS-9-25C).
2. Connect one 24 VAC wire from the right side of the circuit board in the power supply box to the first 24 VAC terminal on the remote alarm printed circuit board (PCB).
3. Connect the other 24 VAC wire from the right side of the power supply box to the second 24 VAC terminal on the remote alarm PCB.
4. Connect a jumper wire from the 24 VAC terminal used in step 3 to the common (C) terminal on the power supply.
5. Connect a signal wire from the normally open (N/O) terminal on the Power supply to the GAS 1 terminal on the remote alarm PCB.
6. Connect the Second terminal on the left side of the power supply to the common terminal on the pressure switch.
7. Connect the fourth terminal on the left side of the power supply to the normally open (N/O) terminal on the pressure switch.

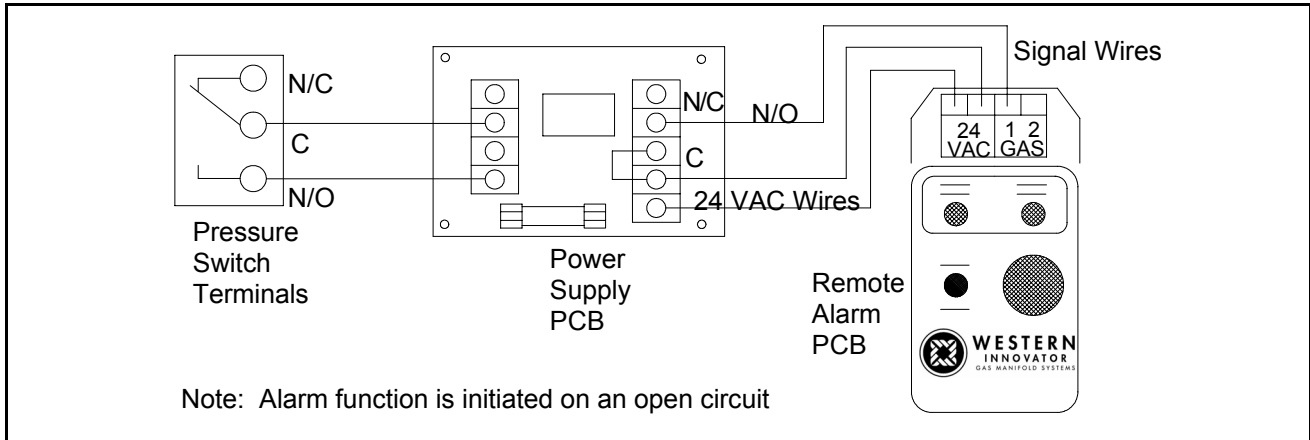

FIGURE 7 Western's Remote Alarm

**In some instances the power supply for the remote alarm is normally a part of the electrical contract on proposed constructions and exists in any furnished hospital. The following procedure should be followed:**

1. Two alarm signal wires requiring dry contacts should run to the manifold location.
2. Connect one signal wire to the common (C) terminal on the pressure switch. (Figure 8)
3. Connect the other signal wire to the normally open (N/O) terminal on the pressure switch.

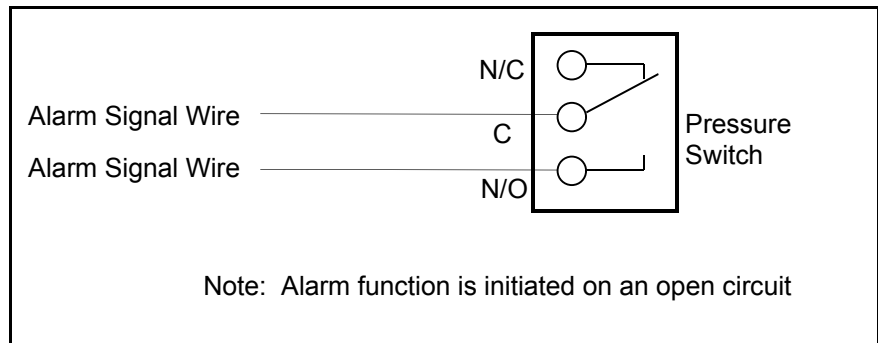

FIGURE 8 Signal Wire Installation

**If the remote alarm requires a power supply for operation, then connect the alarm as follows:**

(Also see WESTERN'S ALARM section.)

1. The power supply will be determined by the remote alarm operating voltage. If the remote alarm is designed for 115 VAC service then the existing 115 VAC power source can be utilized directly. (Figure 9)  
If the remote alarm is designed for other than the existing AC power source, then it is necessary to install a transformer in the system to provide the proper operating voltage. (Figure 9)

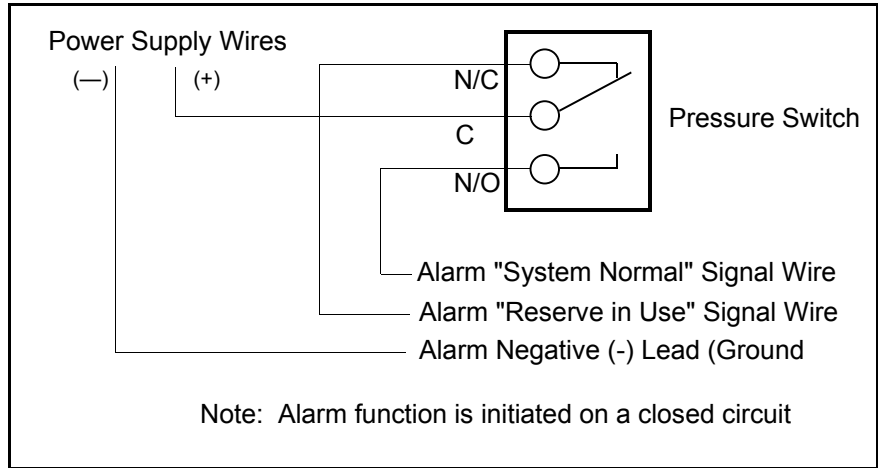

FIGURE 9 115 VAC Power

2. Connect the positive lead (+) from the power supply to the common (C) terminal on the pressure switch.
3. Connect the ground wire from the alarm to the negative (-) lead from the power supply.
4. Connect the "reserve in use" signal wire from the alarm to the normally closed (N/C) terminal on the pressure switch.
5. If a "system normal" signal is also employed, connect that signal wire to the normally open (N/O) terminal on the pressure switch.

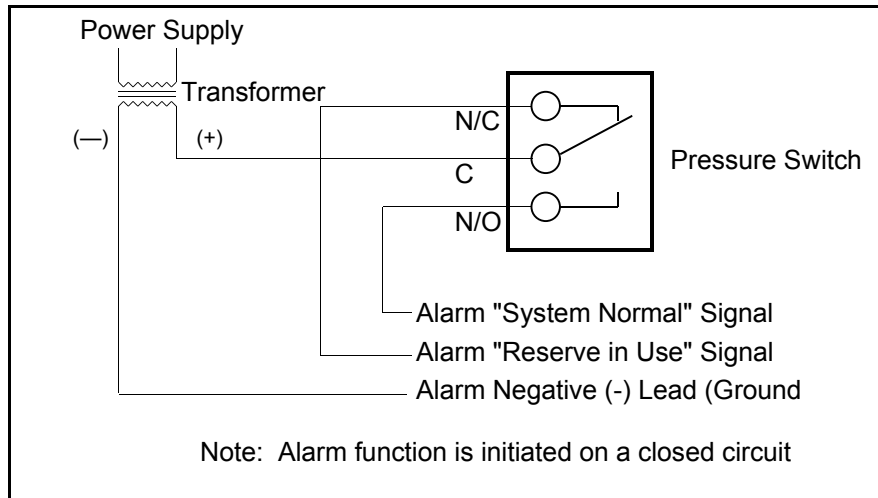

FIGURE 10 User Supplied Power

**START UP AND CHECKING PROCEDURES**

1. The LA series manifolds are designed to provide an increased supply of gas as well as higher flow rates than can be achieved using a single cylinder.
2. S-L-O-W-L-Y open the cylinder valves (turn counter-clockwise to open). The high pressure gauge will show the pressure of the bank of cylinders. (Figure 11)
3. Adjust the delivery pressure of the regulator to the desired pressure. The selection of the regulator set pressure may vary due to application requirements. A typical set pressure would be about 25 psig less than the cryogenic cylinder pressure.
4. If a pressure switch has been installed in the system, it should be set at the midpoint between the high pressure regulator and the cryogenic cylinder set pressure.
5. Open the cylinder valve on the cryogenic vessel.
6. Simulate a depleted bank by closing the cryogenic cylinder valves and creating a flow of gas through the manifold. The pressure will drop and gas will start to flow from the high pressure reserve manifold. Any alarms connected to the system monitoring changeover will activate.

7. S-L-O-W-L-Y open the cryogenic cylinder valves (turn counter-clockwise to open).

8. The manifold is now ready to supply your system.

### MANIFOLD OPERATION

The manifold control includes the following components and features: A high pressure manifold consisting of a regulator, flexible pigtails with check valves and a header designed to be easily expanded and a cryogenic manifold consisting of cryogenic flexible pigtails with check valves and a line regulator.

Gas flows from the cryogenic cylinder into the manifold system. This gas flows to the line regulator where the pressure is reduced to the desired line pressure. A check valve prevents the flow of gas back to the high pressure portion of the manifold.

Gas from the high pressure cylinders enters the high pressure manifold header. This gas then enters the high pressure regulator and is reduced to a pressure lower than the cryogenic cylinder pressure.

When the cryogenic cylinder is depleted the gas pressure will drop. When the pressure drops to the high pressure regulator setting, the gas from the reserve high pressure cylinders is permitted to flow. An alarm will sound at this time (optional equipment) signaling that new cryogenic cylinders are required.

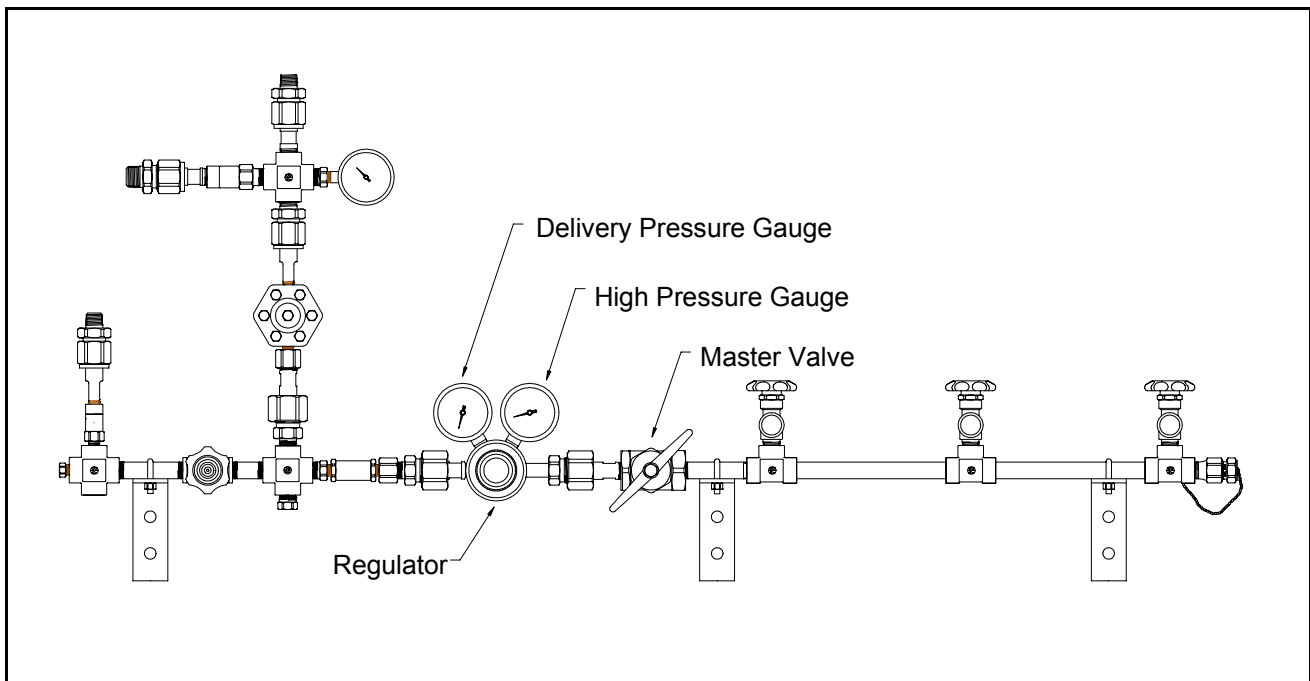

FIGURE 11

To insure proper operation, observe the following guidelines:

1. Carefully follow all instructions.
2. Establish proper flow direction of check valves.
3. Be sure the header master shut-off valve is fully opened.

NOTE: These valves are provided for emergency shut off only.

4. Be sure cylinder valves are fully opened.
5. Replace empty cylinders as soon as practical after the manifold has depleted.
6. Monitor high pressure reserve bank. This bank will be partially depleted when changeover occurs. Since bank is partially depleted there may not be sufficient gas to provide uninterrupted service at the next over cycle.

#### **HIGH PRESSURE CYLINDER REPLACEMENT & HANDLING**

1. Shut off all cylinder valves and header valves on the depleted bank.
2. S-L-O-W-L-Y loosen and remove the pigtail connection from the depleted cylinders.
3. Remove depleted cylinders and replace protective caps.
4. Remove protective cylinder caps from full replacement cylinders. With the valve outlet pointed away from you or anyone else, slowly open each cylinder valve slightly to blow out any dirt or contaminants which may have become lodged into the cylinder valve.
5. Place and secure full cylinders into position using chains, belts, or cylinder stands.
6. Connect pigtails to cylinder valves and tighten with wrench.
7. S-L-O-W-L-Y turn each cylinder valve until each cylinder is fully open.
8. Check all cylinder/pigtail connections for leaks using Western Leak Detector, LT-100 or an equivalent oxygen safe solution. Repair or replace any connections that show signs of bubbles which indicate leakage.
9. The manifold supply bank is now replenished and may be put in service by following instructions on page (START UP AND CHECKING PROCEDURES).

#### **CRYOGENIC CYLINDER REPLACEMENT & HANDLING**

1. Shut off all cylinder valves and the master valve on the depleted bank.
2. S-L-O-W-L-Y loosen and remove the pigtail connection from the depleted cylinders.
3. Remove depleted cylinders and replace protective caps.
4. Remove protective cylinder caps from full replacement cylinders. With the valve outlet pointed away from you or anyone else, slowly open each cylinder valve slightly to blow out any dirt or contaminants which may have become lodged into the cylinder valve.
5. Place and secure full cylinders into position using chains, belts, or cylinder stands.
6. Connect pigtails to cylinder valves and tighten with wrench.
7. Open master valve. S-L-O-W-L-Y turn each cylinder valve until each cylinder is fully on.

NOTE: All cylinders shall have their pressure building regulators set at the same pressure.

8. Check all cylinder/pigtail connections for leaks using Western Leak Detector, LT-100 or an equivalent oxygen safe solution. Repair or replace any connections that show signs of bubbles which indicate leakage.
9. The manifold supply bank is now replenished and is in service.

## GENERAL MAINTENANCE

1. Main section
  - a) Daily - record line pressure.
  - b) Monthly
    - 1) Check regulators and valves for external leakage.
    - 2) Check valves for closure ability.
  - c) Annually - check relief valve pressures.  
- replace regulator seats.
  
2. Manifold header
  - a) Daily - observe nitrous oxide and carbon dioxide systems for cylinder frosting or surface condensation.  
Should excessive condensation or frosting occur it may be necessary to increase manifold capacity.
  - b) Monthly
    - 1) Inspect valves for proper closure.
    - 2) Check cylinder pigtailed for cleanliness, flexibility, wear, leakage, and thread damage. Replace damaged pigtailed immediately.
    - 3) Inspect pigtail check valves for closure ability.
  - c) Every 4 Years
    - 1) Replace all pigtailed

**TROUBLE-SHOOTING**

(Only qualified repair personnel should make repairs)

<b>SYMPTOM</b>	<b>PROBABLE CAUSE</b>	<b>REMEDY OR CHECK</b>
<b>SYSTEM DEPLETES PREMATURELY</b>		
The high pressure reserve depletes prior to cryogenic cylinder(s).	The high pressure manifold regulator is set above the cryogenic cylinder pressure.	Decrease the regulator setting below the cryogenic cylinder pressure.
The high pressure reserve depletes at the same time the cryogenic cylinder depletes.	The high pressure manifold regulator is set too close to the cryogenic cylinder pressure.	Decrease the regulator setting below the cryogenic cylinder pressure.
<b>SYSTEM DOES NOT FLOW</b>		
Manifold does not flow and delivery gauges drop down to 0.	Line regulator set at 0 psig.	Reset the line regulator to desired delivery pressure
<b>LOSS OF CYLINDER CONTENTS</b>		
Audible or inaudible gas leakage (unknown origin).	Leakage at manifold piping connections.	Tighten, reseal or replace.
	Leakage in downstream piping system.	Repair as necessary.
	Leakage at cylinder valve.	Replace cylinder.
	Gauge leaks.	Reseal or replace.
	Regulator leaks.	Repair or replace.
Venting at relief valve.	Regulator setting too high.	Set delivery pressure to specifications.
	Over pressure due to creeping or faulty regulation by regulator.	Replace regulator seat and nozzle components.
	Regulator freeze-up. (Nitrous oxide or carbon dioxide)	Reduce the flow demand or increase the number of supply cylinders.
Gas leakage around regulator body or bonnet.	Loose bonnet.	Tighten bonnet.
	Diaphragm leak on regulator.	Replace diaphragm.

## MANIFOLD MAINTENANCE & REPAIR PARTS

### NOTE:

- Western manifold systems are designed and tested for optimal performance and adherence to safety specifications. We recommend the use of Western replacement components to maintain the standards of performance and the safety of the product.

### REPLACEMENT PIGTAILS

24" Stainless Steel Flexible Braid with Check Valves (High Pressure Bank)

PF-320CV-24R.....	CGA 320 for Carbon Dioxide (CO <sub>2</sub> ) Service
PF-326CV-24R.....	CGA 326 for Nitrous Oxide (N <sub>2</sub> O) Service
PF-63CV-24.....	CGA 540 for Oxygen (O <sub>2</sub> ) Service
PF-92CV-24R.....	CGA 580 for Nitrogen and Argon (N <sub>2</sub> , Ar) Service

24" Synthetic Fiber Braid Hose with Check Valve (High Pressure Bank)

PFS-92CV-24R.....	CGA 580 for Helium (He) Service
-------------------	---------------------------------

72" Cryogenic Flexible Pigtails with Check Valve

WMH-2-5.....	CGA 320 for Carbon Dioxide (CO <sub>2</sub> ) Service
WMH-2-6.....	CGA 326 for Nitrous Oxide (N <sub>2</sub> O) Service
WMH-2-7.....	CGA 540 for Oxygen (O <sub>2</sub> ) Service
WMH-2-8.....	CGA 580 for Nitrogen, Argon and Helium (N <sub>2</sub> , Ar, He) Service

### REGULATORS AND REGULATOR REPAIR KITS

RM-4-4.....	Primary Regulator for CO <sub>2</sub>
RM-7-4.....	Primary Regulator for Argon, Nitrogen and Helium
RM-8-4.....	Primary Regulator for N <sub>2</sub> O
RDM-9-4.....	Primary Regulator for Oxygen
RWC-3-49.....	Replacement Cartridge for RM-7-4, RM-4-4, RM-8-4,
RWC-2-19.....	1st Stage Replacement Cartridge for RDM-9-4
RWC-2-36.....	2nd Stage Replacement Cartridge for RDM-9-4
WMR-6-4.....	Cryogenic Line Regulator (LA and LAMP series)
WMR-6-6.....	Cryogenic Line Regulator (LAHP series)
RK-1070.....	Repair kit for WMR-6-4 and WMR-6-6

### VALVES AND VALVE REPAIR KITS

WMS-1-53.....	CGA 540 Spud Check Valve	WMV-2-14.....	CGA 326 Header Valve
WMV-2-16.....	Master Valve	WMV-2-3.....	CGA 580 Header Valve
WMV-2-7.....	CGA 320 Header Valve	RK-1085.....	Repair Kit for WMV-2-16
WMV-2-69.....	Cryogenic Master Valve		

## LIMITED WARRANTY

WARRANTY: The Seller expressly warrants that the products manufactured by it will be free from defects in material, workmanship and title at the date of shipment. This Warranty is exclusive and is IN LIEU OF ALL IMPLIED OR STATUTORY WARRANTIES (INCLUDING WITHOUT LIMITATION, WARRANTIES AS TO MERCHANTABILITY OR FITNESS FOR A PARTICULAR PURPOSE, OR ARISING FROM COURSE OF DEALING OF USAGE OR TRADE) or any other express or implied warranties or representations. All claims under this warranty must be made in writing and delivered to the Seller prior to the expiration of 1 year from the date of shipment from the factory, or be barred. Upon receipt of a timely claim, the Seller shall inspect the item or items claimed to be defective, and Seller shall, at its option, modify, repair, or replace free of charge, any item or items which the Seller determines to have been defective at the time of shipment from the factory, excluding normal wear and tear. Inspection may be performed at the Seller's plant and in such event, freight for returning items to the plant shall be paid by Buyer. Seller shall have no responsibility if such item has been improperly stored, installed, operated, maintained, modified and/or repaired by an organization other than the Seller. adjustments for products not manufactured by Seller shall be made to the extent of any warranty of the manufacturer or supplier thereof. The foregoing shall be the Seller's sole and exclusive liability and Buyer's sole and exclusive remedy for any breach of warranty or for any other claim based on any defect in, or non-performance of, the products whether based on breach of contract or in tort, including negligence or strict liability.



**WESTERN**  
INNOVATOR

875 Bassett Road  
Westlake, Ohio 44145-1142  
(440) 871-2160  
(800) 783-7890  
FAX: (440) 835-8283  
[www.westernenterprises.com](http://www.westernenterprises.com)